

SECTION 6.2_DST-100 / DST-200

N² BLANKETING VALVE

INTRODUCTION

The model DST-100 and DST-200, N² Blanket gas controller, helps gas pressure to maintain in constant state in the vapor space of storage Tanks. When liquid run out from storage vessel or vacuum state take place because of temperature dropping, N² Blanket gas controller has a ability of control desired pressure within the fixed limits. Besides above subjects, prevents air and humidity from entering into storage vessel, So it can preserve products, and also protect from a fire. It protects the tank from explosion by restricting spark. It prevents the outflow of fluid by evaporation.

Blanketing Capacity

DST-100 (DN 15 ~ DN 25)	Min. 179 ~ Max. 1060 Nm ³ /hr for Nitrogen
DST-200 (DN 32 ~ DN 50)	Min. 465 ~ Max. 2760 Nm ³ /hr for Nitrogen

Body Materials SS304 and SS316 with various trims

Sizes range DN 15, 20, 25, 40, 50 with ASME 150Lb flanges (Other connection all available)

Rules & Certifications API 2000 7th Edition - "Calculation for Highest requirements with no flame arrester for Inert-gas-Blanketing"

APPLICATION

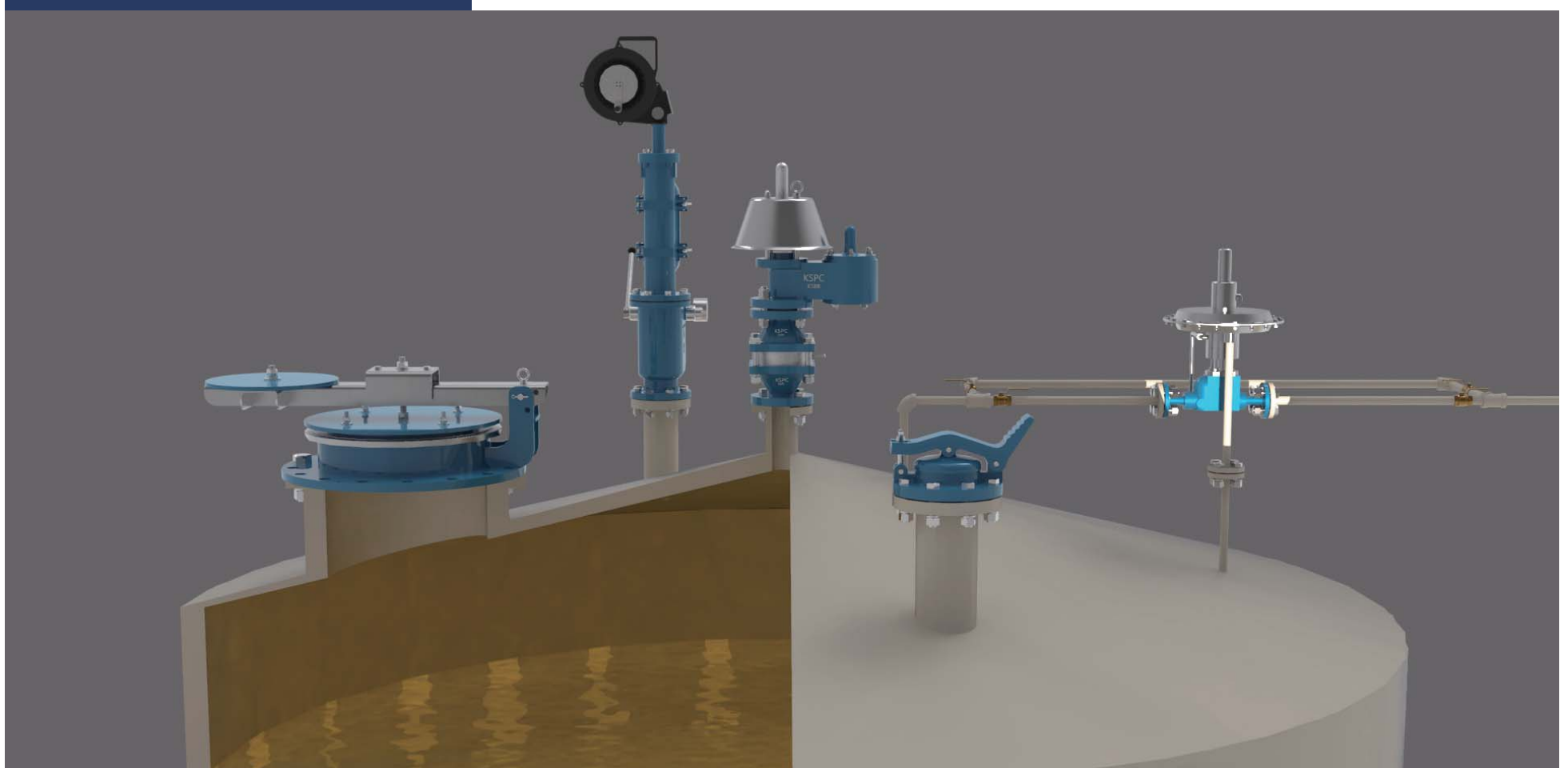

OUTLINE DRAWING

DST-100

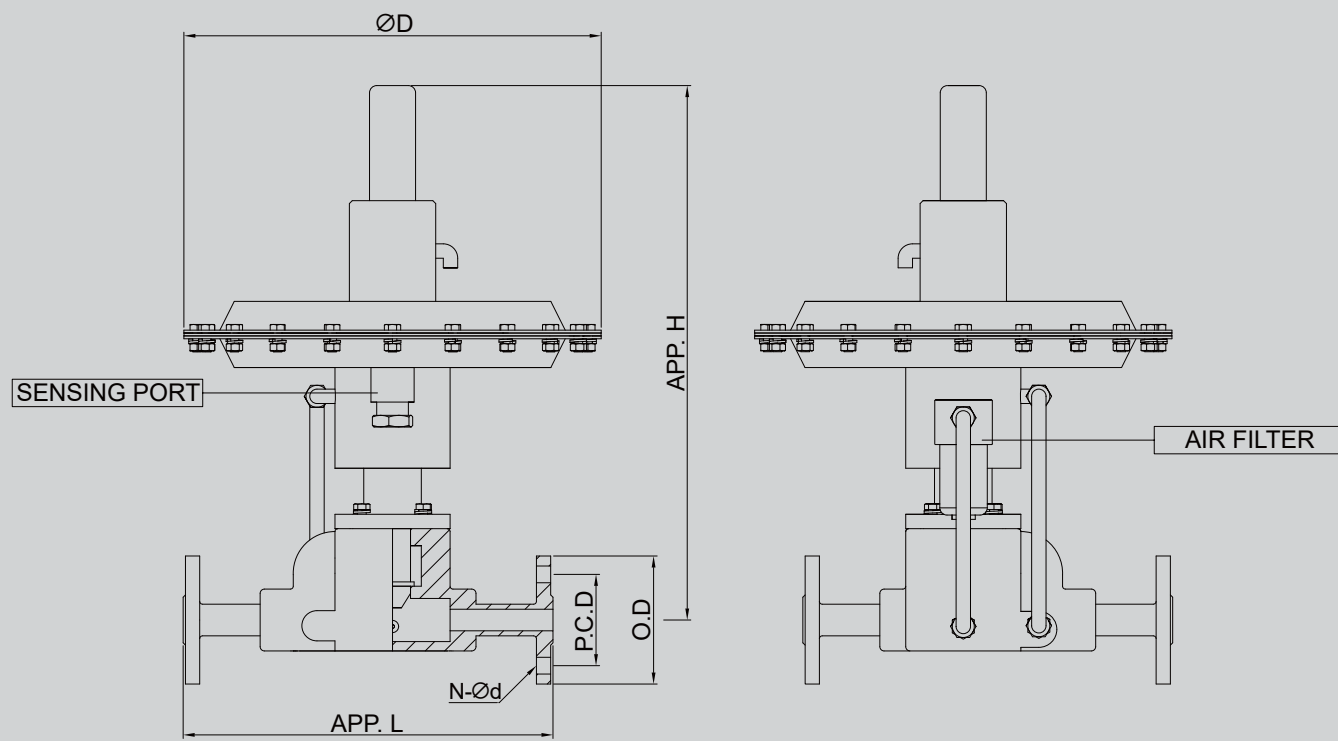

DST-200

DIMENSION TABLE

SIZE	DST-100				DST-200	
	½" (15A)	¾" (20A)	1" (25A)	1¼" (32A)	1½" (40A)	2" (50A)
N.D	15	20	25	32	40	50
App. L	260	260	260	340	340	340
App. H	370	370	370	430	430	430
P.C.D	60.3	69.9	79.4	88.9	98.4	120.6
O.D	89	98	108	117	127	152
ØD	310	310	310	310	310	310
N-Ød	4-Ø16	4-Ø16	4-Ø16	4-Ø16	4-Ø16	4-Ø19

NOTE Standard Connection(ASME 150lb flange) and JIS or different types are available upon request.

CAPACITY TABLE

INPUT PRESSURE (kg/cm ² G)		1.5	2	2.5	3	3.5	4	4.5	5	6	6.5
Capacity in Nm ³ /hr for Nitrogen	DST 100 (½"~1")	179	230	260	295	335	387	435	460	545	570
	DST 200 (1¼"~2")	465	595	630	745	875	1005	1140	1280	1411	1460

INPUT PRESSURE (kg/cm ² G)		7	7.5	8	8.5	9	9.5	10	11	12	13
Capacity in Nm ³ /hr for Nitrogen	DST 100 (½"~1")	595	645	690	720	750	800	853	945	1000	1060
	DST 200 (1¼"~2")	1546	1680	1780	1870	1950	2085	2220	2355	2490	2760

GENERAL SPECIFICATION

MODEL	DST-100	DST-200
SIZE	½" ~ 1"	1" ~ 2"
SET PRESSURE	30 ~ 5000mmW.C	
CONNECTION	FNPT / ASME 150# & 300#, Etc	
MATERIAL	SS304, SS316, Etc.	
USED GAS	N2 (Nitrogen)	
SENSING PORT	NPT ½"	

TECHNICAL SPECIFICATION

SET PRESSURE		MINIMUM INLET PRESSURE	TEMP.
1.2 ~ 1.4" W.C	1.3 ~ 3.1 psi	22 psi (1.5 kg/cm ² G)	-20 to +149°C
3.5 ~ 10" W.C	2.3 ~ 3.5 psi		
8 ~ 18" W.C	3.0 ~ 6.0 psi		