



## SECTION 7.2\_KS 115

# PILOT OPERATED PRESSURE RELIEF VALVE VENT TO ATMOSPHERE

### INTRODUCTION

 **The model KS 115** is Pilot Operated Pressure Relief Valve discharges the volume flow without requiring pressure increase. Basically, Pilot valves are used for the valve shall be highly tight sealed up to the set pressure figures. The pilot valves provide the capacity to meet API standard 2000.

### Setting Pressure

KS 115 Permanent Setting	Min. + 50 mmW.C ~ Max. + 9,000 mmW.C
--------------------------	--------------------------------------

 **Body Materials** Carbon Steel, SS304 and SS316 with various trims  
(Different materials available on request)

 **sizes range** DN 50 ~ DN 300 with ASME 150Lb as Standard  
(Different connections available on request)

 **Rules & certifications** API 2000

 **Optimum / optional Design & Arrangements** Steam jacket type, Proximity type, Teflon Coating /Lining type

### APPLICATION



## OUTLINE DRAWING

**KS 115**

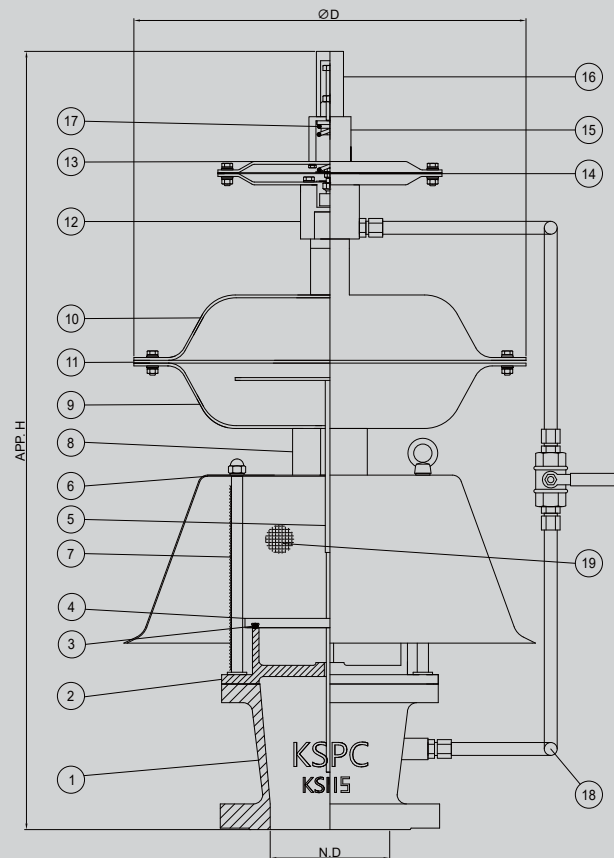

## DIMENSION TABLE

SIZE	2"	3"	4"	6"	8"	10"	12"
N.D	50	80	100	150	200	250	300
ØD	420	420	420	420	420	420	420
App. H	715	745	782	819	840	876	896

**NOTE** Standard Connection(ASME 150Lb flange) and JIS or different types are available upon request.

## COMPONENT MATERIAL

ITEM NO	COMPONENT	BODY	CARBON STEEL	SS304	SS316
		TRIM	SS304	SS304	SS316/316L
1	BODY		A216-WCB	A351-CF8	A351-CF8M
2	SEAT		A351-CF8	A351-CF8	A351-CF8M
3	O-RING		VITON (NOTE)		
4	DISC ASS'Y		SS304	SS304	SS316L
5	DISC COVER		SS304	SS304	SS316L
6	HOOD		SS304	SS304	SS316L
7	PRESSURE GUIDE		SS304	SS304	SS316
8	PRESSURE COVER HANDLE		SS304	SS304	SS316L
9	LOWER COVER		SS304	SS304	SS316L
10	UPPER COVER		SS304	SS304	SS316L
11	COVER DIAPHRAGM		VITON (NOTE)		
12	PILOT BODY		SS304	SS304	SS316L
13	PILOT COVER		SS304	SS304	SS316L
14	PILOT DIAPHRAGM		TEFLON (NOTE)		
15	PILOT HANDLE BODY		SS304	SS304	SS316L
16	PILOT HANDLE		SS304	SS304	SS316L
17	SPRING		SS304	SS304	SS316
18	SENSING LINE		SS304	SS304	SS316L
19	BIRD SCREEN		SS304	SS304	SS316

**NOTE** Other materials are available upon request.



Section 7.2  
KS 115